

Power Controller EFS



EFS

- 3-phased power controller
- Output loads up to 44 kW (88 kW)
- Supply voltage 230V or 400V AC
- Zero transition triggering
- Built-in signal converter
- Adjustable period time
- Built-in relay to double the power output
- Built-in P-controller
- Modulating output reduction of excessive temperature
- Heat sink can be built into duct
- Long life expectancy

Application

The EFS is applied when an accurate and electrical noiseless regulation of major electrical heating outputs is required, e.g. heating surfaces in ventilation systems and industrial plants. It can also be applied for regulation of ceiling, floor and radiant heating etc. The EFS can be mounted in such a way that the heat sink can be built into airducting. The pulse period time can be set between 1-40 secs, which makes the EFS usable for control of infrared heating elements.

The EFS has a built-in P-controller and thus constitutes a compact output controller for instance for floor heating systems.

The newest technology has been used to ensure a low thermic load and a long life expectancy (5 x life expectancy of a traditional solid-state relay).

There are 2 variants of the EFS: EFS-9xx2 (2 thyristors) for installations with symmetrical load and EFS-9xx3 (3 thyristors) for unsymmetrical load.

Double the output: The EFS has a built-in relay, which makes it possible to double the output by use of 2 heating elements of equal size.

Function

The EFS is an electronic time proportional power controller with two or three heavy thyristor outputs with zero transition triggering for 3-phased voltage. The EFS transforms a signal to a pulse/pause proportion of the switched on/off output. For example if the control signal is 5V the output will be switched on for 50% of the period time, which is adjustable. Other types of control signals can be used. The output is switched on/off at the zero point of the sine curve thus eliminating electrical noise on radios and TVs.

The EFS has a built-in P-controller and thus constitutes a compact output controller for e.g. floor heating systems. The EFS has a built-in signal converter and can be connected to an external controller with voltage or power output.

Safety functions

Galvanic separation between output unit and control signal.

Limit thermostat: The EFS has a built-in limit thermostat which modulates the output load at excessive temperature in the power controller (the period on-time is reduced), i.e. in case of minor excessive temperature it is still possible to make a regulation, but with reduced maximum output. Active in the range 80-85°C.

Thermal fuse: Furthermore the EFS has a thermal fuse which zero's the control signal at internal temperature above 90°C. As soon as the temperature is normal again, the control signal will be switched on automatically.

Product program

Type	Product
EFS-9252	Power controller 25A, 230/10 kW, 400V / 17 kW
EFS-9402	Power controller 40A, 230/16 kW, 400V / 28 kW
EFS-9632	Power controller 63A, 230/25 kW, 400V / 44 kW
EFS-9253	Power controller 25A, 230V/10 kW, 400V / 17 kW
Accessories	
EFSA-1	Flange for duct mounting
EFSA-5	Bracket for DIN-rail mounting

LED indication

- 1 MAIN LED1 (green) Indicates that supply is on.
- 2 OUT LED2 (green) Indicates voltage on the load.
- 3 LIMIT LED3 (yellow) Constant light means that limit is active.
Flashing means sensor failure.
- 4 STEP LED4 (green) On when the step relay is active.



Technical data

Inputs

Supply voltage	50-60 Hz, 230/400V AC \pm 10%
Voltage signal	0-10V DC
Voltage signal	2-10V DC
Impedance (voltage signal)	10K ohm
Current signal	0-20 mA
Current signal	4-20 mA
Voltage loss (current signal)	1V (20 mA)

Outputs

Type EFS-9252	3x25A RMS
- primary fuse max. 1800A ² S	25A
Type EFS-9253	3x25A RMS
- primary fuse max. 450A ² S	25A
Type EFS-9402	3x40A RMS
- primary fuse max. 1800 A ² S	40A
Type EFS-9632	3x63A RMS
- primary fuse max. 6300 A ² S	63A

Further specifications

Output voltage	Pulsating AC-voltage (PWM)
Output switch	Thyristors 1200V
Protection against transients	Built-in varistors
Filter	Built-in filter 150KHz - 30MHz
Thermal fuse	90°C
Temperature limit sensor	80-85°C (limits pulse width on the output voltage)
Period time (external controller)	1-40 secs.
Supply output	+14V / 25 mA for supply of external units (EFRP)
Relay output	Potential free SPST for two heating element system
Built-in controller	Proportional controller with adjustable P-band 1-6°C and a fixed period time 20 secs.
Temperature range	0-40°C
Sensor input	NTC sensor
Load form	Star / delta, ohmic
Min. output load	400W
Power consumption	5VA
Cos (PHI)	0.98
Heat output	EFS-9xx2 approx. 2W/A
	EFS-9xx3 approx. 3W/A
Insulation voltage	2500V RMS
Ambient temperature	-10/+40°C
Housing	IP 20
Standard applied	EN60 947-4-3

Internal P-controller

By connecting an NTC sensor (type ETF-x99x) and setting the EFS on "internal setpoint" (DIP 6) and "controller" (DIP 4) a complete output control is obtained. The required temperature (P1) can be set to 0-40°C, and P-band (P2) can be set on 1-6°C (period time fixed 20 secs.).

By connection to EMRF-99 (room sensor with built-in potentiometer) the adjusted setpoint (P1) can be displaced \pm 5°C.

As an alternative sensor a transducer 0-10V DC (DIP 3 ON) can be applied.

External controller

By setting the EFS on "slave" function (DIP 4) an external controller can be applied. P2 now becomes the pulse/pause time adjustment (1-40 secs) and now P1 is not active.

Functions	DIP-switches
Input Vin1 / I in Dip1, Dip2:	0-10V
	2-10V
	0-20 mA
	4-20 mA
Sensor Vin2 Dip3:	NTC
Transducer Vin2	0-10V
Function Dip4:	External controller
	Internal controller
Relay (step) Dip5:	Not active
	Active (2 heating elements)
Set point Dip6:	External
	Internal

Mounting and connection

The EFS range is mounted on the wall or on panel board. If it is required to mount the EFS on a DIN-rail the bracket EFSA-5 is to be used. By use of bracket EFSA-1 it is furthermore possible to mount the EFS with the heat sink in the duct.

It must be ensured that the controller is sufficiently ventilated. Max. ambient temperature at max output load 40°C.

Control signal

The control cable from external controller can be extended up to 50 m by a separate cable. It must be avoided to place the cable in parallel with other cables. Voltage signals may occur which may interrupt the function of the controller.

It is not always necessary with a shielded cable to the controller, however it improves the immunity of the controller against noise, if it is being used in industrial environment. The shield is connected to terminal 13 (GND).

Short circuit protection

On installation of EFS in a system where a short-circuit may occur, it is recommended that the EFS is protected with a fuse type (Ultra fast), especially suitable for Solid State Relays and semi conductors. A fuse is selected with the voltage and current rating suitable for the output regulator.

Protection against excessive temperature

E.g. in ventilation systems with electrical heating surfaces the system is supplied with a safety thermostat which via contactor will switch out the system if the set value is exceeded. The control input on the EFS must never be used as safety function.



Applications

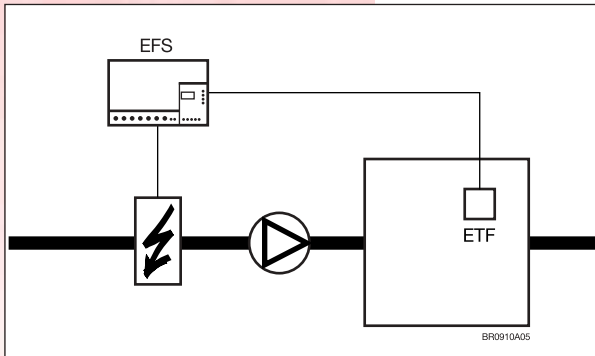

Constant room temperature (internal P-control)

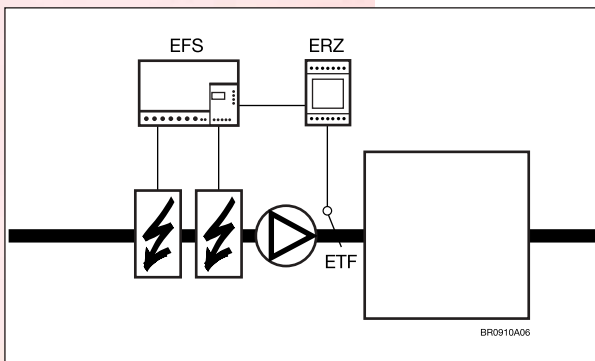

Constant supply air temperature

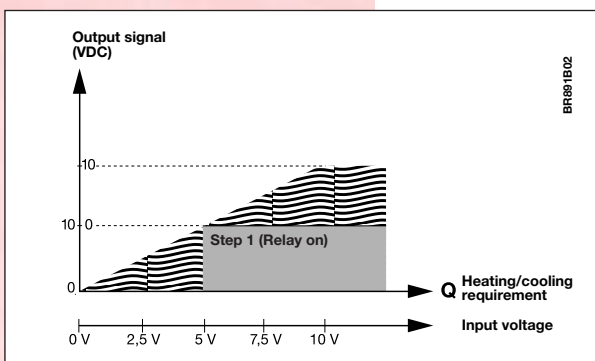

Output doubling with built-in relay

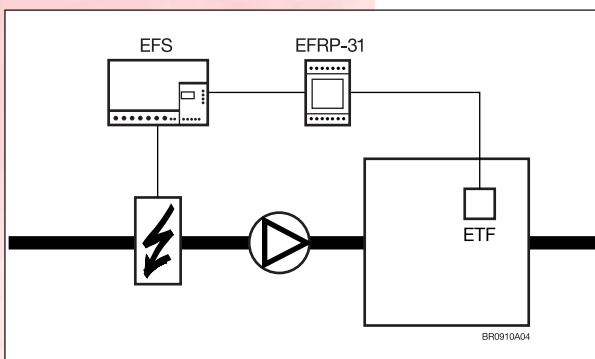

Constant room temperature (external P-controller)

Connections

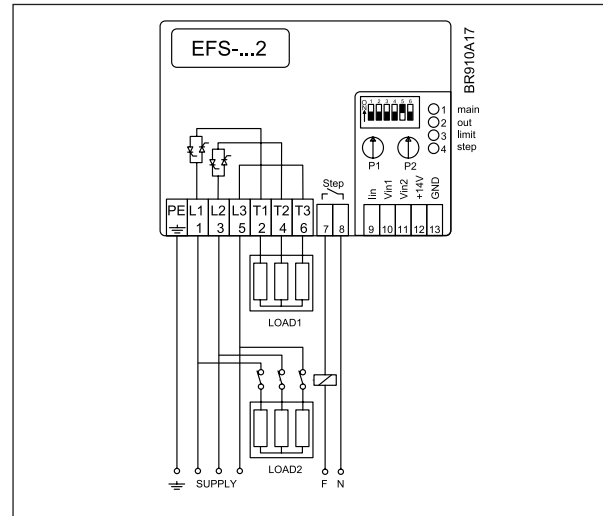

Fig. 1 - Output doubling with built-in relay

Built-in relay for two heating element system

The built-in relay offers the possibility of controlling the double of the nominal output of the EFS, if the output is divided on 2 equal-sized heating elements (DIP 5 OFF). The EFS will modulate the output on one of the heating elements up to 100%. In case of heavier heating requirement the other heating element will be switched on via the relay (see figure 1) and the EFS will then modulate from 0-100% on the first heating element.

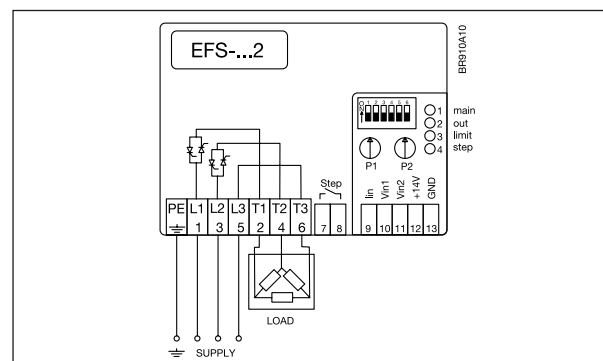

Fig. 2 - Symmetrical load (delta connection)

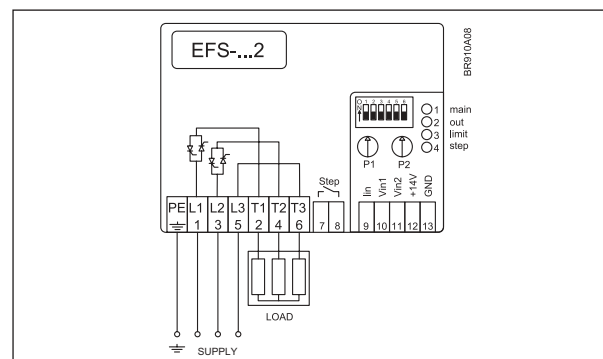

Fig. 3 - Symmetrical load (star connection)

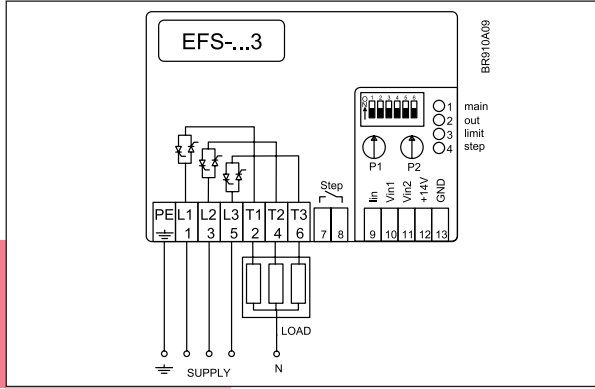

Fig. 4 - Unsymmetrical load (star connection)

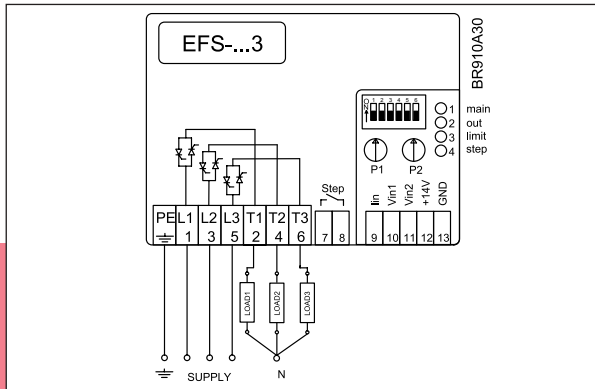

Fig. 5 - 3 x single phase with separate load

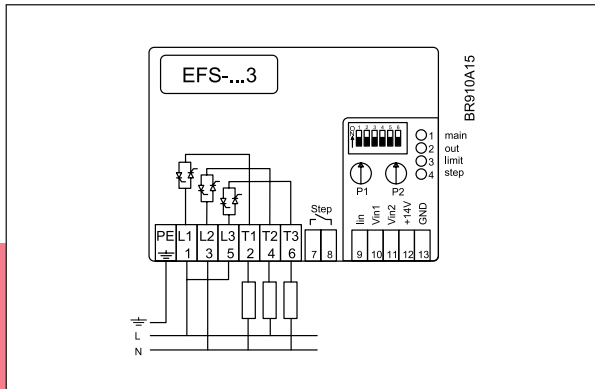

Fig. 6 - Single phase 3 load

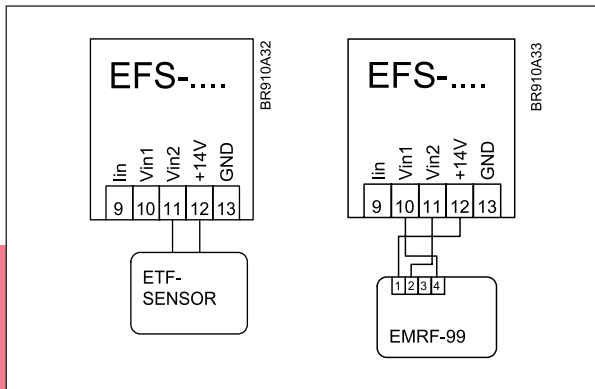

Fig. 7 - Sensor connection for internal P-controller

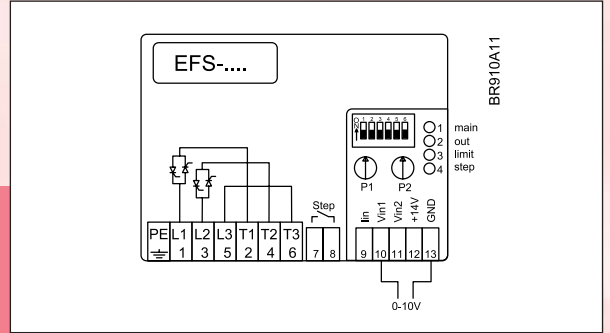

Fig. 8 - Connection of external controller

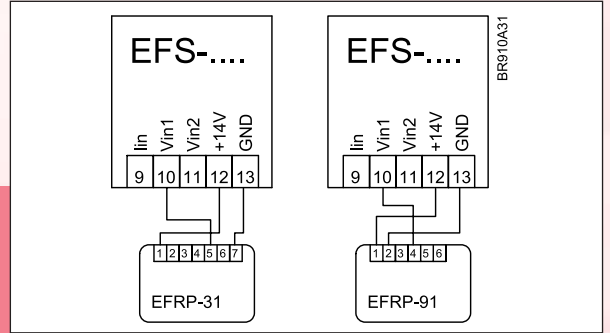
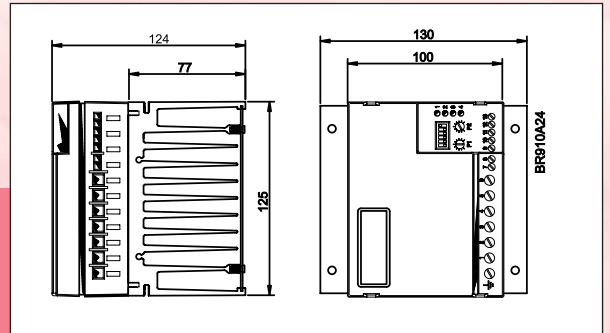
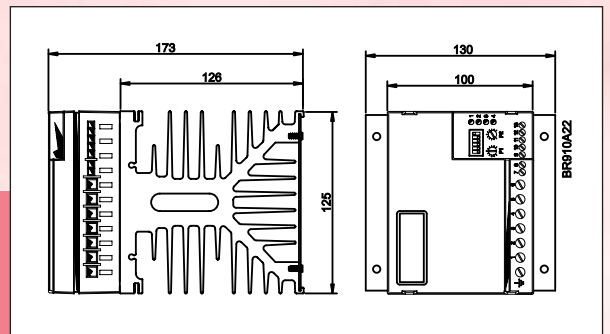

Fig. 9 - Connection of EFRP controller



Dimensions - EFS-9252



Dimensions - EFS-9253 and EFS-9402

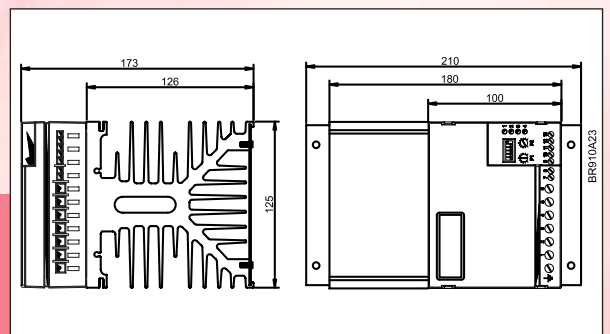

Dimensions - EFS-9632